

ANSI LAMBDA LUBE FREE ROLLER CHAIN

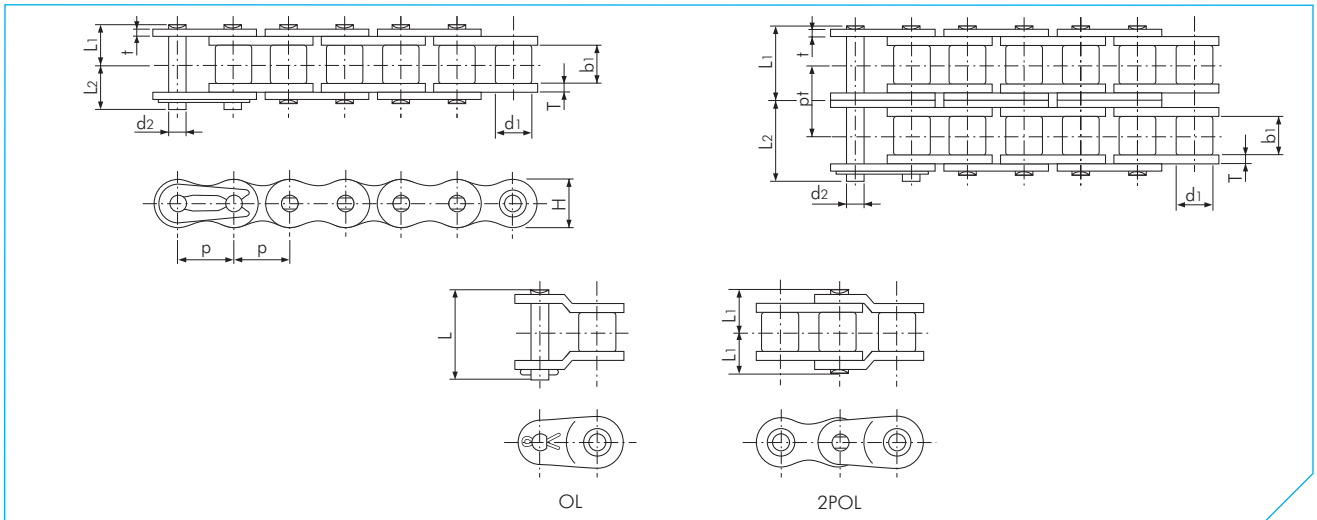

ANSI LAMBDA Chain

Dimensions in mm

TSUBAKI Chain No.	Pitch		Roller Diameter d1	Inner Width b1	Diameter d2	Pin			Link Plate			Transverse Pitch pt	Min. Tensile Strength acc. to Tsubaki kN	Approx. Mass kg/m
	p	(inches)				Length L1	Length L2	Length L	Thickness T	Thickness t	Height H (max)			
RS40-LMD-1	12.70	(1/2")	7.92	7.55	3.97	8.75	10.45	20.00	2.00	1.50	12.00	-	17.7	0.70
RS40-LMD-2						16.50	18.10	-				15.40	35.3	1.40
RS50-LMD-1	15.875	(5/8")	10.16	9.26	5.09	10.75	12.45	24.00	2.40	2.00	15.00	-	28.4	1.11
RS50-LMD-2						20.20	22.00	-				19.00	56.9	2.20
RS60-LMD-1	19.05	(3/4")	11.91	12.28	5.96	13.70	15.70	32.00	3.20	2.40	18.10	-	40.2	1.72
RS60-LMD-2						26.05	28.05	-				24.52	80.4	3.40
RS80-LMD-1	25.40	(1")	15.88	15.48	7.94	17.15	20.25	39.90	4.00	3.20	24.10	-	71.6	2.77
RS80-LMD-2						32.70	35.90	-				31.10	143.0	5.50
RS100-LMD-1	31.75	(1 1/4")	19.05	18.70	9.54	20.65	23.85	47.50	4.80	4.00	30.10	-	107.0	4.30
RS100-LMD-2						39.50	42.50	-				37.60	214.0	8.60
RS120-LMD-1	38.10	(1 1/2")	22.23	24.75	11.11	25.75	29.95	59.00	5.60	4.80	36.20	-	148.0	6.40
RS140-LMD-1	44.45	(1 3/4")	25.40	24.75	12.71	27.70	32.20	63.70	6.40	5.60	42.20	-	193.0	8.10

Note:

1. Connecting links are clip type for sizes RS40-LMD to RS60-LMD, and cotter type for sizes RS80-LMD to RS140-LMD.
2. Drive and Conveyor series LAMBDA chain cannot be intercoupled or interchanged.
3. Due to increased roller link plate thickness, Drive LAMBDA connecting links are required.
4. Due to increased roller link plate thickness, LAMBDA double strand chains require special sprockets.
5. Due to increased roller link plate thickness, the pins are longer. Check for machine interference.
6. Offset links for LAMBDA double strand chains are not available.
7. When a single pitch offset link is used, please calculate a 35% reduction in fatigue strength.
8. Also available in NEPTUNE™ specification.

ANSI LAMBDA LUBE FREE ROLLER CHAIN

TSUBAKI's LAMBDA Chains were the first in the industry to use a special oil impregnated bush. Since their launch in 1988, they have been adopted for diverse industries and applications, and their performance has been highly rated. TSUBAKI has a wide line-up of lube-free, long life products that help customers reduce costs.

Technical Evolution

As a pioneer in the lube-free chain market, TSUBAKI will reveal some of the key elements behind ANSI LAMBDA's outstanding performance:

Sintered Bush

A special NSF-H1 oil impregnated sintered bush in combination with a special coated pin for long-term internal lubrication is the secret of TSUBAKI ANSI LAMBDA's long economic life and wear resistance.

Ring Coining Process

Breakage of the chains connecting link is no issue at TSUBAKI thanks to this unique feature. By applying the Ring Coining process, TSUBAKI generates a cold deformation around the pin hole of the connecting link plate. This results in residual stress around the pin hole and thereby adds strength. By using this process transmission capacity is increased to 100% of the base chain.

Special Environments

TSUBAKI ANSI LAMBDA has outstanding performance in temperatures up to +150°C.

For temperatures above +150°C: Due to the special NSF-H1 certified lubrication impregnated bushes, TSUBAKI ANSI LAMBDA KF Series is usable in a wide temperature range (from -10°C to +230°C) while at the same time being kind to the environment. Please consult TSUBAKI for more detailed information.

Advantages

TSUBAKI has enhanced the ANSI LAMBDA with the following advantages:

Save Maintenance Costs

No expensive labour costs as it is not required to manually lubricate this chain.

Save Purchasing Costs

Lower frequency of purchasing due to the high quality of the chain and its long economic life. No purchasing of lubricants or lubrication systems necessary.

Higher Productivity

No unforeseen downtime due to chain breakdown.

Less time required for maintenance and therefore more time for production.

Environmental Friendly

Applications run clean thus reducing the risk of contaminating products, machines, floor etc. In addition, the LAMBDA chain is ideally suited for food industry applications due to the use of a NSF-H1 lubricant.

Interchangeability

Sprockets:

Only simplex ANSI roller chain sprockets are interchangeable. Multi strand sprockets need to be customised due to the thickness of the roller link plates.

Due to the extended lifetime of ANSI LAMBDA chain, TSUBAKI advises to install sprockets with hardened teeth in every LAMBDA application.



Fig. 14 Basic Construction

